

CATALOGO PARTI DI RICAMBIO
 CATALOGUE OF SPARE PARTS
 CATALOGUE PIECES DE RECHANGE
 ERSATZTEILKATALOG
 CATALOGO DE PIEZAS DE REPUESTO

FOTO O DISEGNO DEL
 MOTOCICLO vem

CODICE MOTOCICLO	38-67500-0-97	250cc
MOTORCYCLE COD.	38-67530-0-97	400cc
REF. CICLO A VITESSE	38-67510-0-97	450cc
FAHRENG CODE	38-67520-0-97	525cc
CODIGO MOTOCICLO		

DAL N. TELAIO	ZD3E1000040000001
FROM FRAME N.	ZD3E1010040000001
DE NUMERO CADRE	ZD3E1020040000001
AB FAHRGESTELNUMMER	ZD3E1030040000001
DESDE NUMERO CHASSIS	

Forcella
Front fork
Fourche avant
Gabel
Horquilla

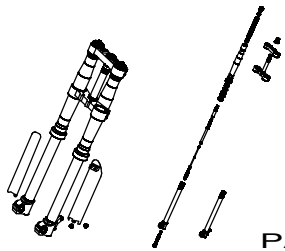

PAG. 3

Manubrio
Handlebar
Guidon
Manillar
Manillar

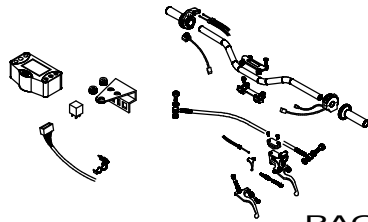

PAG. 4

Telaio
Frame
Cadre
Fahrgerüst
Chassis

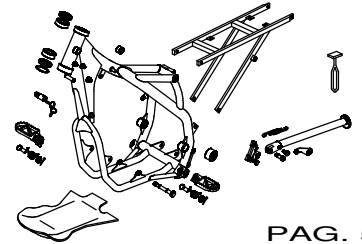

PAG. 5

Forcellone
Swinging arm
Bras oscillant
Schwingarm
Basculante

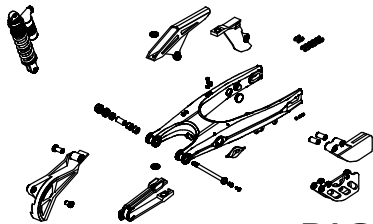

PAG. 6

Silenziatore e Marmitta
Silencer and muffler
Silencieux et pot d'ecchapp.
Auspuff
Silenciador

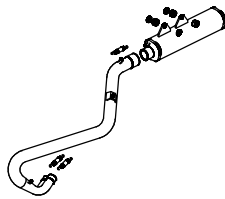

PAG. 7

Filtro e scatola aspirazione
Filter and injection box
Filtre et
Luftfilter und filterkasten
Filtro y escatula aspiracion

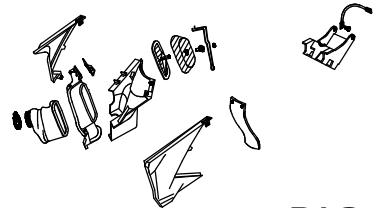

PAG. 8

Ruota anteriore
Front wheel
Roue avant
Vorderrad
Rueda delantera

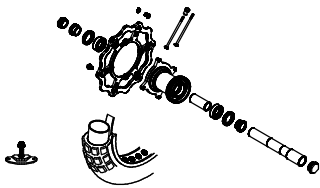

PAG. 9

Ruota posteriore
Rear wheel
Roue arriere
Hinterrad
Rueda trasera

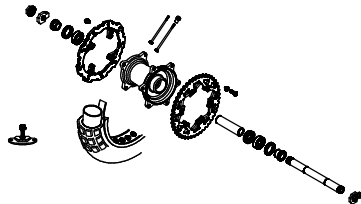

PAG. 10

Freni
Brakes
Freins
Bremsen
Frenos



PAG. 11

Parafanghi
Fenders
Garde-boues
Kotflügel
Guardabarras

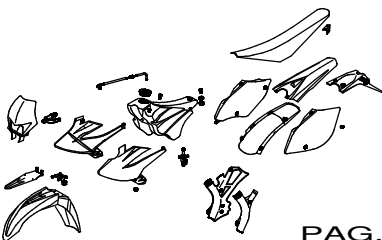

PAG. 12

Bilanciere
Bumper rod
Balancier
Schwinghebel
Balance

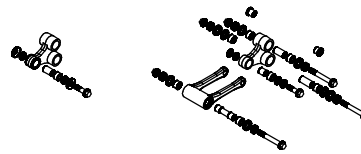

PAG. 13

Impianto elettrico
Electrical system
Installation électrique
Elektrische anlage
Instalacion electrica

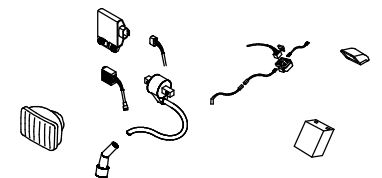

PAG. 14

Radiatore
Radiator
Radiador
Kühler
Radiador

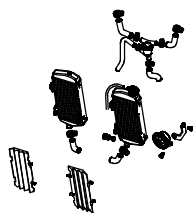

PAG. 15

Particolari non figuranti
Not mentioned particulars
Particuliers pas mentionnes
Nicht verzeichnete teile
Particulares no figurados

PARTICOLARI NON FIGURANTI
SUPPLEMENTARY PARTS LIST
PARTICULIERS PAS MENTIONNES
NICHT VERZEICHNETE TEILE
PARTICULARES NO FIGURADOS

PAG. 16

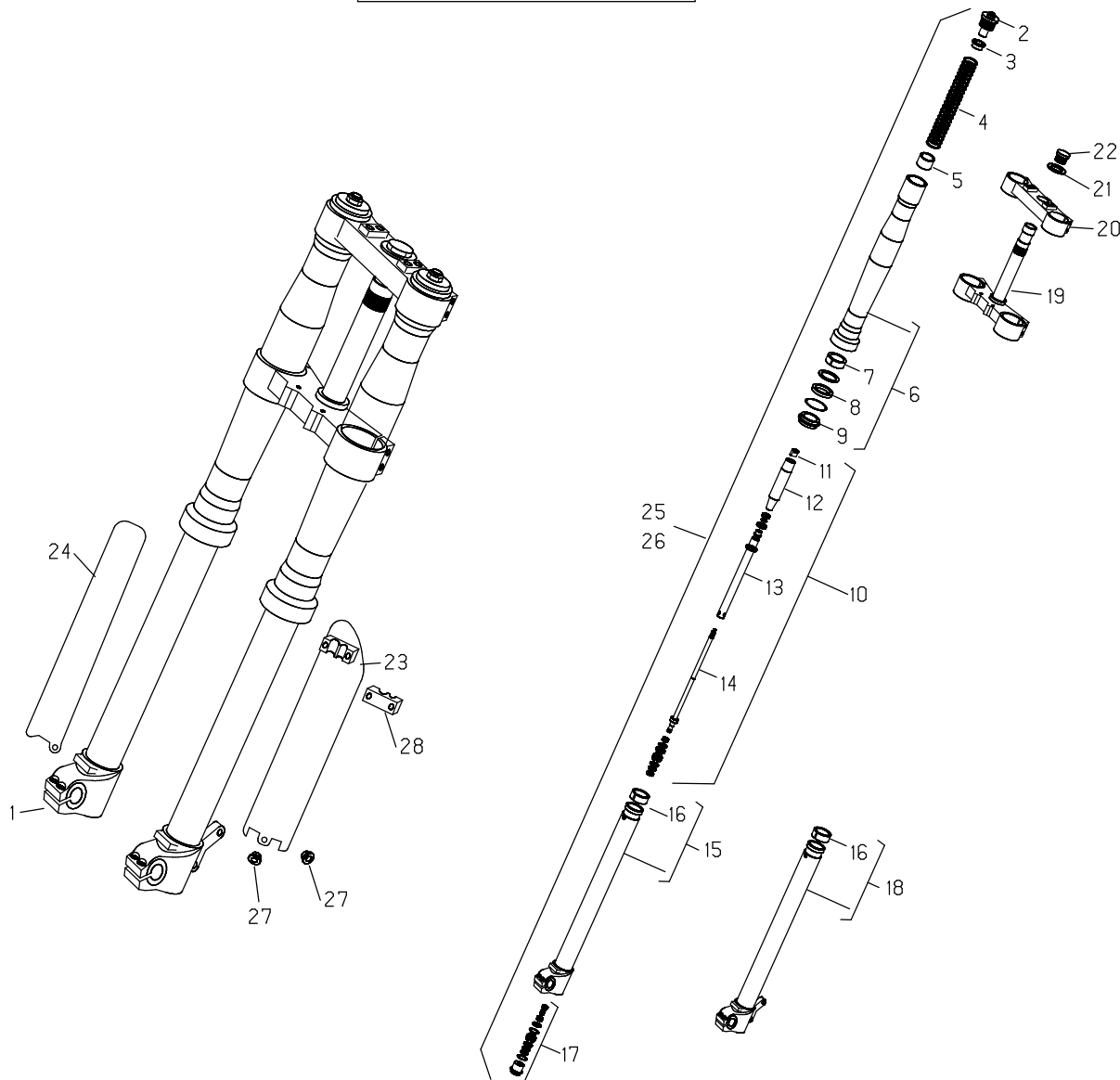

Pos	Number	Descrizione	Description	Description	Beschreibung	Descripción
1	15-08050	Forcella RR-4T	Front fork RR-4T	Fourche	Gabel RR-4T	Horquilla compl.
2	29-01965	Tappo forcella	Fork cover	Bouchon fourche	Gabel Stopfen	Tapon horquilla
3	10-41476	Anello per molla forcella	Front fork spring ring	Joint ressort fourche	Gabelsfederring	Junta muelle horquilla
4	22-52704	Molla forcella	Fork spring	Ressort fourche	Gabel Feder	Muelle horquilla
5	29-40464	Tubo precarico molla forcella	Fork spring tube	Tube ressort fourche	Federschlauch Gabel	Tubo muelle horquilla
6	16-18655	Gamba forcella	F/fork leg	Jante fourche	Gabelbein	Bravo horquilla
7	11-31310	Boccola superiore forcella	F/fork up. Bush	Douille superieure fourche	Gabelsbuchse oben	Casquillo superior horquilla
8	10-41462	Anello di tenuta forcella	Fork oil seal	Bague d'etancheite fourche	Dichtring RSU-Gabel	Junta horquilla
9	10-41477	Anello raschiapolvere forcella	F/fork dust ring	Bague de fourche	Staubkappe	Junta horquilla
10	12-32974	Cartuccia meccanica forcella	Kit mechanic spares fork	Cartouche mecanique fourche	Gabeldaempfer	Cartucho mecanica horquilla
11	13-29530	Dado spec. Forcella	F/fork spec. Nut	Ecrou spec. Fourche	Gabel spezial Mutter	Tuerca esp. Horquilla
12	29-40463	Tubo guidamolla forcella	Fork spring tube	Tube ressort fourche	Federschlauch Gabel	Tubo muelle horquilla
13	12-32959	Cartuccia forcella (custodia)	Fork spares	Cartouche fourche	Gabeldaempfer	Cartucho horquilla
14	12-32973	Cartuccia forcella (asta)	Fork spares	Cartouche fourche	Gabeldaempfer	Cartucho horquilla
15	29-40423	Tubo dx completo forcella	RH compl. Fork tube	Tube compl. Droit fourche	Gabelstandrohr rechts	Tubo derecho compl. Horquilla
16	11-31311	Boccola interna forcella	F/fork int. Bush	Douille interieure fourche	Gabelsbuchse innen	Casquillo interior horquilla
17	31-02175	Valvola fondo gamba forcella	Fork leg valve	Valve jante fourche	Gabelsbeinsicherung	Valvula brazo horquilla
18	29-40424	Tubo sx completo forcella	LH compl. Fork tube	Tube compl. Gauche fourche	Gabelstandrohr links	Tubo izquierdo compl. Horquilla
19	12-09702	Crociera con cannotto	Lowe yoke	Croisiere a/tube fourche	Untere Gabelbrücke	Pletina con tubo
20	29-50152	Testata forcella	Fork head	Tete fourche	Obere gabelbrueke	Culata horquilla
21	27-79102	Rondella forcella	Fork washer	Rondelle fourche	Gabel Scheibe	Arandela horquilla
22	13-30965	Dado 20x1,5 per forcella	F/fork 20x1,5 nut	Ecrou 20x1,5 fourche	Gabel Mutter 20x1,5	Tuerca horquilla 20x1,5
23	25-98895-1-97	Protezione tubo forcella sx	LH fork tube protection	Protection tube fourche gauche	Abdeckung Gabelschlauch li.	Protection tubo horquilla izquierd
24	25-98894-1-97	Protezione tubo forcella dx	RH fork tube protection	Protection tube fourche droit	Abdeckung Gabelschlauch re.	Protection tubo horquilla derecho
25	16-00978	Gamba forcella sx completa	Complete left fork leg	Jante gauche compl. fourche	Gabelbein li.	Bravo horquilla izquierdo compl.
26	16-00979	Gamba forcella dx completa	Complete right fork leg	Jante droit compl. Fourche	Standrohr re	Bravo horquilla derecho compl.
27	13-54820	Distanziale 6,5/9/13,5x4,8	Spacer	Entretoise	Distanz	Distanciad
28	25-91330-1-97	Ponticello tubo freno	Brake pipe sprocket	Etrier tube frein	Bügel Bremsschlauch	Abrazadera tubo freno

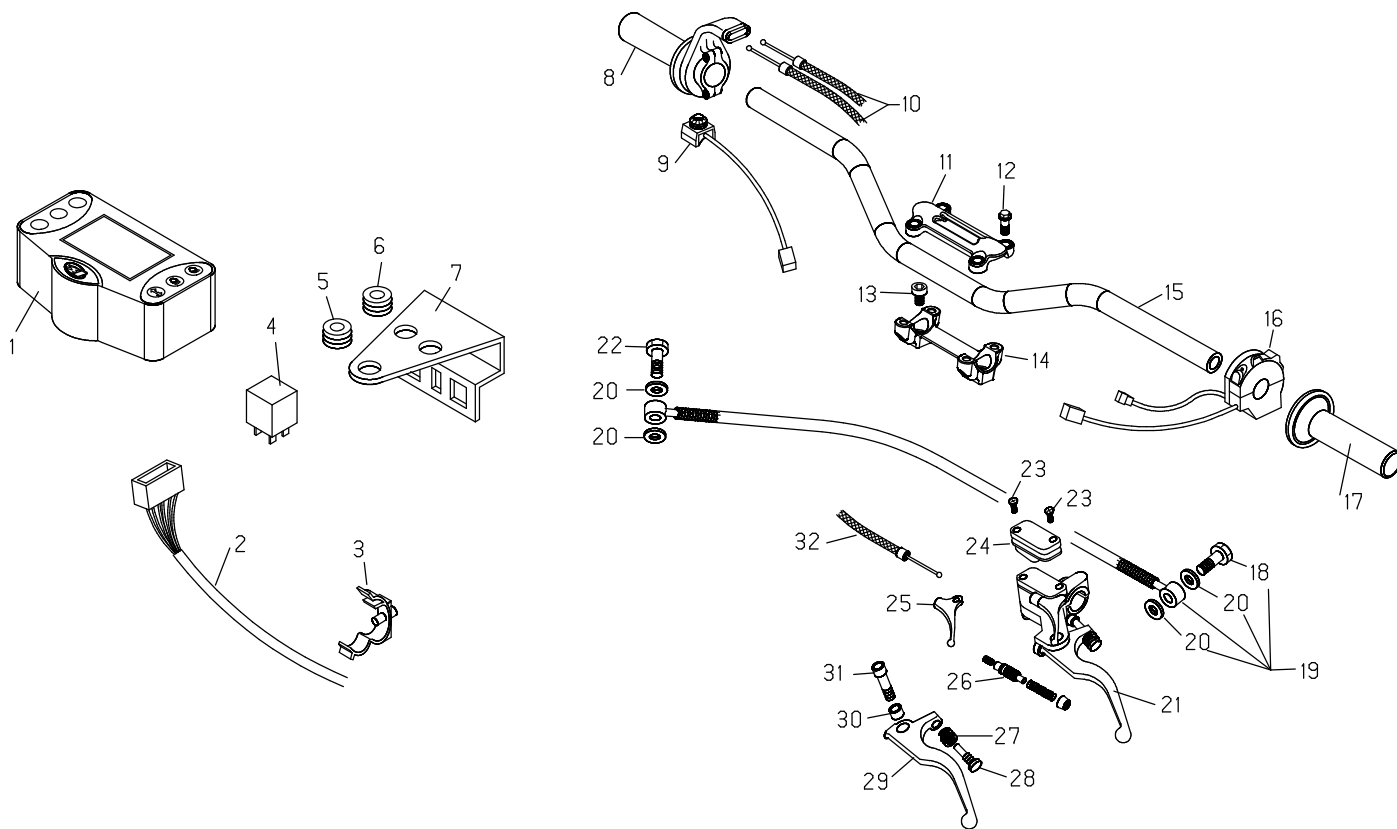

Pos	Number	Descrizione	Description	Description	Beschreibung	Descripción
1	12-09367	Conta-km	Speedometer	Compteur	Tachometer	Cuenta km. tr.
2	18-01525	Impianto centrale	Electric equipment	Systeme electrique	Zentraler Kabelbaum	Instalacion electrica
3	25-24444	Passacavo a scatto d.19	Fair lead d.19	Passe-fils d.19	Kabelführung fahrgest	Pasa-cable d. 19
4	18-84946	Intermittenza	Flasher	Intermittence	Intermittenz	Intermitencia
5	16-34905	Gommino staffa conta-km	Bracket rubber	Caoutchouc etrier compteur	Gummi Tachometersbügel	Goma abrazadera cuentakilometr
6	16-34905	Gommino staffa conta-km	Bracket rubber	Caoutchouc etrier compteur	Gummi Tachometersbügel	Goma abrazadera cuentakilometr
7	28-98068	Supporto strumenti	Instruments support	Support instruments	Halter Werkzeuge	Soporte instrumentos
8	12-55097	Comando gas	Twist grip	Commande gaz	Gasgriff	Mando gas
9	18-84982	Interruttore avviamento	Start switch	Interruptor demarrage	Starterschalter	Interruptor arranque
10	29-15188	Trasmissione gas	Throttle cable	Cable gas	Gaszug	Cable transmision gas
11	12-08253	Cavallo superiore forcella	Upper handlebar bracket	Crampillon superieur fourche	Lenkerböcke Gabel oben	Abrazadera superior horquilla
12	31-64070	Vite flangiata 8x25 ch10	Screw 8x25	Vis avec bride 8x25 ch10	Schraube 8x25	Tornillo especial 8.30
13	31-65626	Vite brugola 10x25 t.b.	Screw 10x25	Vis 10x25	Schraube 10x25	Tornillo 10x25
14	12-08254	Cavallo inferiore forcella	Lower handlebar bracket	Crampillon inferieur fourche	Lenkerböcke Gabel unten	Abrazadera inferior horquilla
15	22-20388	Manubrio	Handlebar	Guidon	Lenker	Manillar
16	13-06506-8	Dip luci e frecce	Device	Dispositif feux et indicateurs	Licht- und Blinkerschalter	Dispositivo luces y flechas
17	22-18537	Manopole (coppia)	Grips (pair)	Poignees (couple)	Lenker Griffe	Puños goma (juego)
18	11-65049	Bullone forato	Special bolt	Boulon	Hohlschraube F.Bremse	Tornillo esp.
19	29-09102	Tubo frizione Idraulica	Clutch hose	Tube embrayage	Kupplungsleitung	Tubo embrague hidraulico
20	16-50510	Guarnizione 10x15x1 in rame	Gasket 10x15x1 copper	Joint 10x15x1 cuivre	Dichtung 10x15x1 Kupfer	Junta 10.15.1 (cobre)
21	21-02427	Leva com. frizione	Clutch lever	Levier complet embrayage	Kupplungsarmatur	Bomba embrague
22	11-65035	Bullone forato 10x1	Special bolt	Boulon 10x1 x tube frein	Hohlschraube F.Bremse	Tornillo esp. talad.10.1
23	31-23401-0-52	Vite coperchio serbatoio olio	Screw	Vis couvercle reservoir huile	Schraube	Tornillo tapa deposito aceite
24	20-05076	Kit serbatoio olio pompa	Oil seal cover for pump	Jeu reservoir huile pompe	Reparatursatz Bremsarmatur	Tubo deposito bomba aceite
25	21-70146	Levetta alzavalvola	Valve lever	Levier valve	Sicherungshebel	Palanca valvula
26	20-05084	Kit pistoncino pompa	Piston kit for pump	Kit petit piston pompe	Reparatursatz Brems/Kupplungs	Kit pistón bomba
27	22-38702	Molla registro leva freno ant.	Front brake lever adjust spring	Ressort enregistrement levier	Feder	Muelle regul. bomba freno
28	31-88602	Vite registro leva frizione	Clutch lever screw	Vis levier embrayage	Schraube	Tornillo palanca embrague
29	21-27085	Leva com.friz.nuda	Clutch lever only	Levier complet embrayage nue	Kupplungshebel	Maneta embrague
30	11-26466	Boccola x leva	Bush	Douille	Buchse	Casquillo
31	31-96819	Vite spec. per leva	Special screw	Vis	Schraube	Tornillo
32	29-13060	Trasmissione alzavalvola	Valve transmission	Transmission valve	Sicherungsantrieb	Trasmision valvula

RR-4T

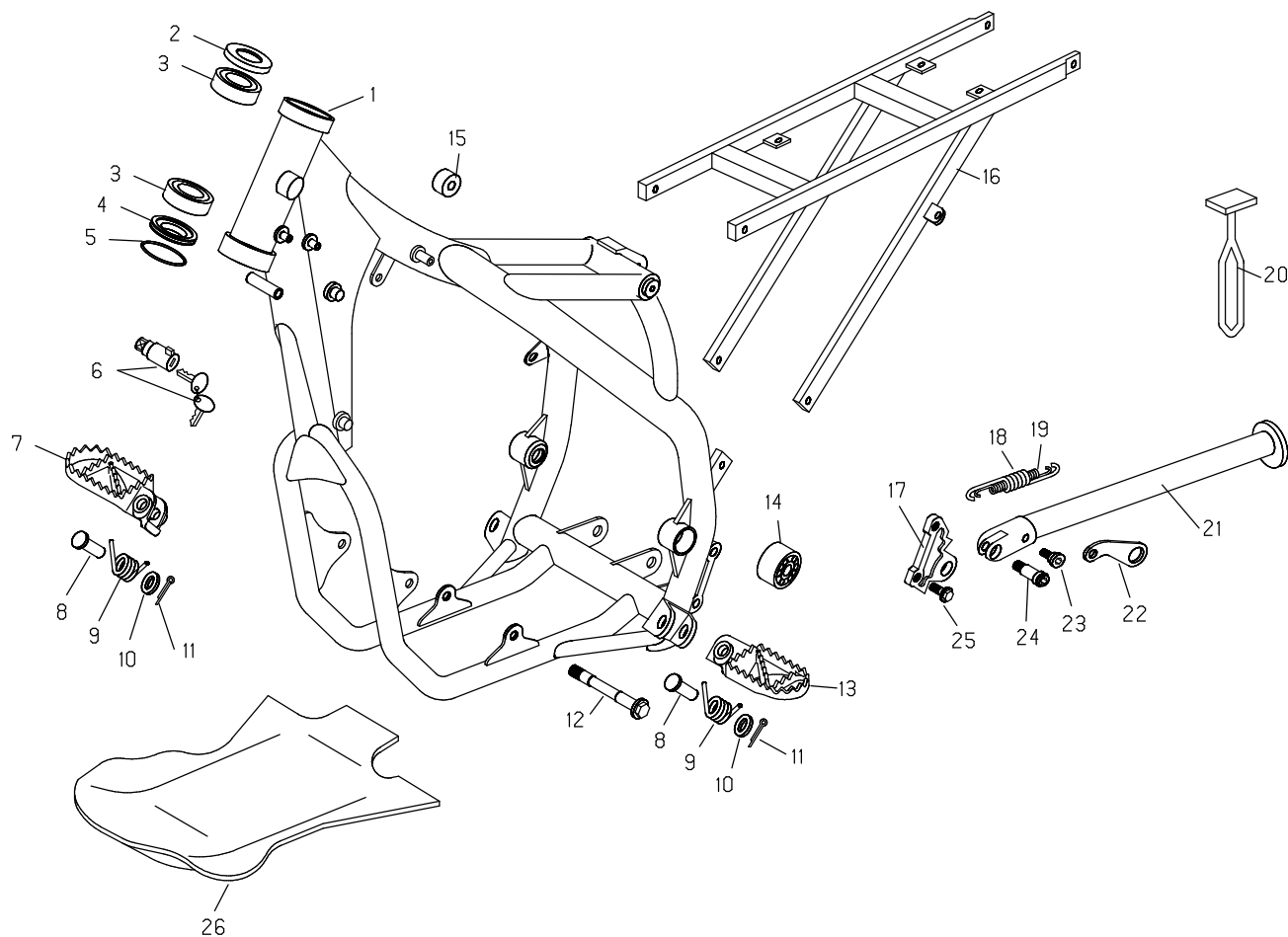

Pos	Number	Descrizione	Description	Description	Beschreibung	Descripción
1	29-11537-8-25	Telaio anteriore	Front frame	Cadre avant	Gutschrift Rahmen	Chasis
2	25-98782	Protezione cuscinetto sterzo	Ball-bearing protection	Protection roulement guidon	Abdeckung Lenkerlager	Protection cojinete manillar
3	12-99510	Cuscinetto conico 29x50x15	Conical bearing 29x50x15	Roulement conique 29x50x15	Lager 29x50x15	Cojinete conico 29.50.15
4	10-67535	Anello parapolvere forcella	F/fork ring	Cache poussiere fourche	F/Gabel Aluminium Ring	Junta guardapolvo direccion
5	10-66935	Anello OR	OR	OR	O-Ring	Junta torica
6	28-85861	Serratura bloccasterzo	Lock	Serrure blocage guidon	Lenkradschloss	Cerradura bloque manillar
7	25-32521	Pedana poggiapiedi dx	RH footrest	Repose-pieds droit	Fußraste re.	Estribera dhc
8	25-54465	Perno pedana	footrest pin	Pivot repose-pied	Rasten Pin	Eje estribera
9	22-62011	Molla pedana dx e sx	RH and LH footerest spring	Ressort repose-pied droit et gauche	Rasten/Feder re. und li.	Muelle derecha y izquierda estribera
10	27-54000	Rondella 10x21x2	Washer 10x21x2	Rondelle 10x21x2	Scheibe 10x21x2	Arandela 10x21x2
11	12-81993	Coppiglia 3x20	Split pin 3x20	Goupille 3x20	Splint 3x20	-
12	11-64607	Bullone spec. motore	Special bolt	Boulon spec.	Spezial Bolzen	Tornillo special
13	25-32531	Pedana poggiapiedi sx	LH footrest	Repose-pieds gauche	Fußraste li.	Estribera izq.
14	27-79431	Rotella guidacatena	Chaine roller	Galet guide de chaine	Rädchen Ketteführung	Arandela cadena
15	29-10310	Tampone serbatoio	Tank rubber pad	Tampon reservoir	Benzintank Schlegel	Tampon deposito
16	29-11433-8	Telaio posteriore	Rear frame	Cadre arriere	Rahmen hinten	Chasis posterior
17	28-97305	Staffa supporto cavalletto	Stand support bracket	Etrier support bequille	Klemme Seitenständer	Soporte caballete
18	22-48819	Molla cavalletto esterna	External stand spring	Ressort bequille exterieure	Seitenständer feder außen	Muelle caballete exterior
19	22-48818	Molla cavalletto interna	Inner stand spring	Ressort bequille interieure	Seitenständer feder innen	Muelle caballete interior
20	16-34907	Gommino ritenuta cavalletto	Stand rubber	Caoutchouc bequille	Gummi Seitenständer	Goma caballete
21	12-39896	Cavalletto	Stand	Bequille	Seitenständer	Caballete
22	25-57636	Piastrina per molla cavalletto	Stand spring plate	Plaquette ressort bequille	Halteplatte Seitenständersfeder	Placa muelle caballete
23	11-66612	Bullone spec. piastr. cavall.	Special bolt	Boulon spec.	Spezialschraube	Tornillo especial
24	11-66611	Bullone spec. cavalletto	Special bolt	Boulon spec.	Spezialschraube	Tornillo especial
25	11-54521	Bullone 8x16 rs c/rond. ch10	Bolt 8x16 ch10	Boulon 8x16 rs a/rondelle ch10	Schraube 8x16 ch 10	Tornillo 8.16 rs c/arandela
26	12-32207	Carter parasassi	Bumper	Bas moteur	Bodenplatte	Cubrecarter

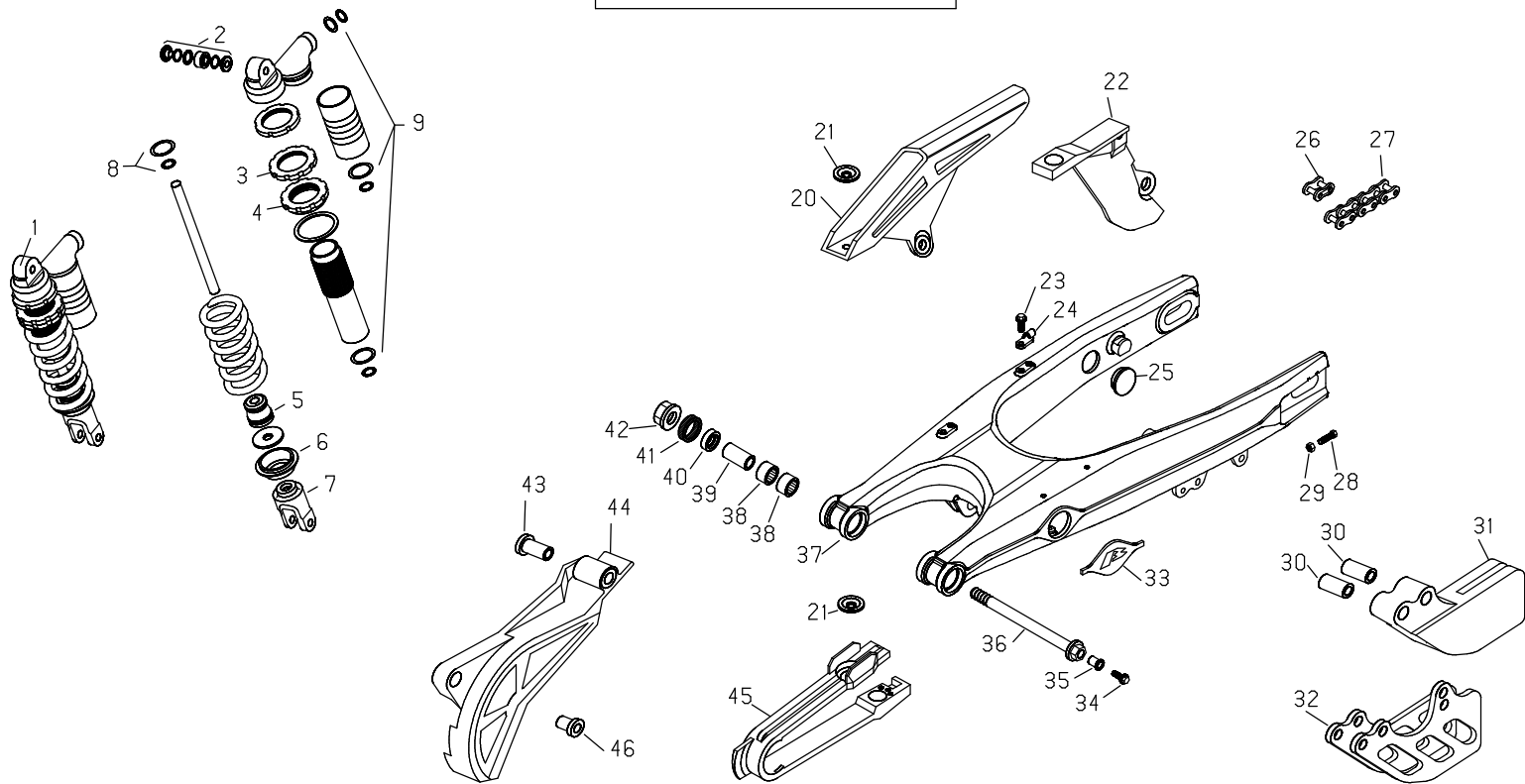

Pos	Number	Descrizione	Description	Description	Beschreibung	Descripción
1	10-03782	Ammortizzatore	Shock absorber	Ammortisseur	Stossdämpfer	Amortiguador
2	13-86078	Distanziali ammortizzatore	Spacer	Entretoise	Distanzscheibe	Distanciator
3	16-20821	Ghiera fissaggio ammortizz.	Shock absorber fixing ring nut	Bague fixation amortisseur	Befestigungsring stossdämpfer	Junta fijadora amortiguador
4	16-20820	Ghiera registro ammortizz.	Shock absorber adjusting ring nut	Bague réglage amortisseur	Regulierungsring stossdämpfer	Junta regularización amortiguador
5	29-10308	Tampone battuta ammortizz.	Shock absorber limit stop plug	Tampon fin course amortisseur	Stossdämpferanschlag	Tampón fin carrera amortiguador
6	15-39110	Fodero copristelo ammortizz.	Leg protection	Train flottage couvre-tige amm.	Federteller Stossdämpfer	Protector amortiguador
7	16-47280	Gruppo forchetta ammortizz.	Shock absorber inf. Connection	Exation inférieur amortisseur	Untere befestigung stossdämpfer	Fijador inferior amortiguador
8	20-11505	Kit gruppo guarniz.stelo amm.	Shock absorber slider gasket set	Joints tige amortisseur	Dichtungssatz hy. Einsatz stossdämpfer	Juego juntas cartucho amortiguador
9	20-11504	Kit gruppo guarniz. Ammort.	Shock absorber gasket set	Joints amortisseur	Dichtungssatz stossdämpfer	Juego juntas amortiguador
20	12-88591-1-36	Copricatena superiore	Up. Chain cover	Couvre-chaîne superieur	Kettenschutz oben	Cubrecadena superior
21	27-74786	Rondella bombata	Washer	Rondelle	Scheibe	Arandela
22	12-88592-1-36	Copricatena inferiore	Inf. Chain Cover	Couvre-chaîne inferieur	Kettenschutz unten	Cubrecadena inferior
23	11-46360	Bullone 5x16 ch 8 rs	Bolt 5x16	Boulon 5x16 ch 8 rs	Bolzen 5x16	Tornillo 5x16 llave 8 rs
24	15-14605	Fascetta tubo freno	Clamp	Collier tube frein disque	Schelle F. Bremsschlauch	Brida fijación tubo freno
25	29-10596-1-36	Tappo forcellone D:30	Swinging arm plug d.30	Bouchon bras oscillant d.30	Stopfen Schwinge D. 30	Tapon basculante d. 30
26	22-11223	Maglia congiunz. 5/8x1/4 (CZ)	Connecting link 5/8x1/4 (CZ)	Maillon jonction 5/8x1/4 (CZ)	Kettenschloss 5/8x1/4 (CZ)	Eganche cadena 5/8.1/4 (CZ)
	22-11224	Maglia congiunz. 5/8x1/4	Connecting link 5/8x1/4	Maillon jonction 5/8x1/4	Kettenschloss 5/8x1/4	Eganche cadena 5/8.1/4
27	12-08204	Catena 5/8x1/4 p.112	Chain 5/8x1/4 p.112	Chaîne 5/8x1/4 p.112	Kette 5/8x4 p.112	Cadena 5/8x1/4 p.112
	12-08206	Catena 5/8x1/4 p.114	Chain 5/8x1/4 p.114	Chaîne 5/8x1/4 p.114	Kette 5/8x4 p.114	Cadena 5/8x1/4 p.114
28	11-55909	Bullone 8x55 pf ch10	Bolt 8x55	Boulon 8x55 pf ch10	Bolzen 8x55	Tornillo 8.55 pf ch 10
29	13-17121	Dado spec. M8 flangiato ch10	Nut M8 special ch10	Ecrou M8 bride ch10	Mutter M8 SW 10	Tuerca M8 esp. Llave 10
30	13-49191	Distanziale	Spacer	Entretoise	Distanz	Distanciator
31	29-10069	Tassello guidacatena infer.	Lower sliding block	Cheville guide de chaîne inf.	Schwingschleifklotz unten	Protector cadena inferior
32	25-98922-8	Protezione tassello guidacat.	Sliding block cover	Protection goujon guide de chaîne	Abdeckung Ketteführungstück	Protección taco cadena
33	29-10597-1-36	Tappo forcellone D:35	Swinging arm plug d.35	Bouchon bras oscillant d.35	Stopfen Schwinge D. 35	Tapon basculante d.35
34	11-46401	Bullone 5x20 ch 8 rs	Bolt 5x20	Boulon 5x20 ch 8 rs	Bolzen 5x20	Tornillo 5x20 llave 8 rs
35	16-29620	Gommino fissaggio	Fixing grommet	Caoutchouc fixation	Befestigungsgummi	Goma fijación
36	25-47652	Perno forcellone	S/arm spindle	Pivot bras ascillant	Schwingenachse	Eje basculante
37	15-49637	Forcellone	Swinging arm	Bras oscillant	Schwinge	Basculante
38	11-22056	Boccola a rulli 22x 12 V	Needle bearing 22x 12 V	Douille a roulements 22x 12 V	Nadellager 22x12 V	Cojinete 22x12 V
39	13-49183	Distanziale forcellone	Spacer	Entretoise bras oscillant	DistanzSchwingenlagerung	Distanciator basculante
40	28-14081	Scodellino forcellone	Swinging arm lever	Cuvette bras oscillant	Schwinge Teller	Sopero basculante
41	10-64481	Anello paraolio 25x32x7	Oil seal 25x32x7	Joint spy 25x32x7	Wedi 25x32x7	Junta aceite 25x32x7
42	13-27121	Dado spec. forcellone	Swinging Arm special nut	Ecrou spec. Bras oscillant	Schwinge spezial Mutter	Tuerca esp. Basculante
43	13-49189	Distanziale	Spacer	Entretoise	Distanz	Distanciator
44	12-73077-1-36	Coperchio pignone catena	Sprocket cover	Couvercle pignon de chaîne	Deckel Ketteritzel	Tapa
45	29-10068	Tassello guidacatena super.	Upper sliding block	Cheville guide de chaîne sup.	Schwingschleifklotz oben	Protector cadena superior
46	13-49190	Distanziale	Spacer	Entretoise	Distanz	Distanciator

RR-4T

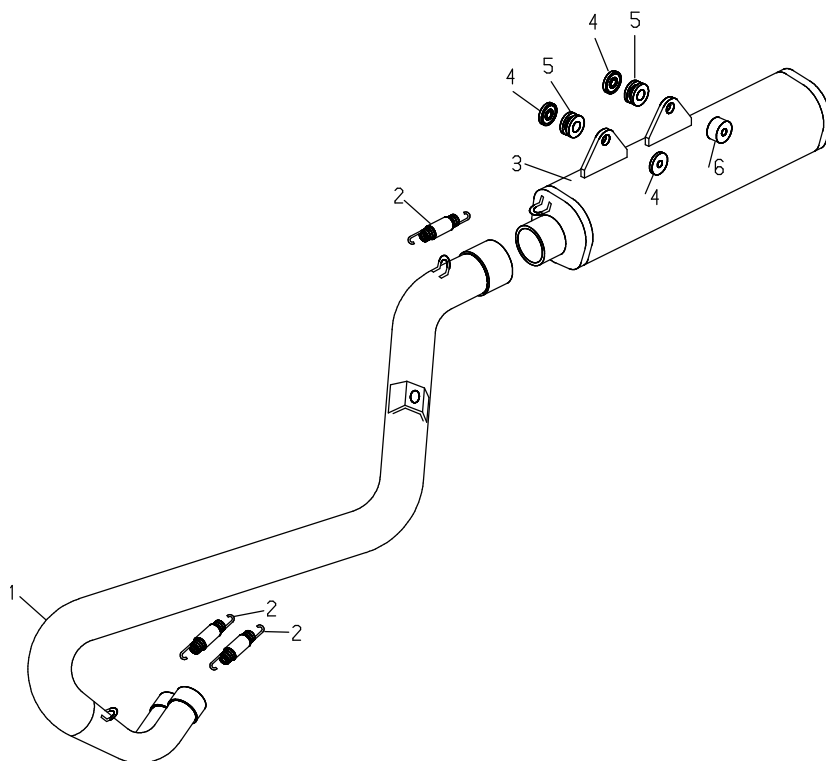

PER 250cc - FOR 250cc - POUR 250cc - FUER 250cc - POR 250cc

Pos	Number	Descrizione	Description	Description	Beschreibung	Descripción
1	29-16234	Tubo scarico	Exhaust tube	Tube vidange	Krümmen	Tubo escape parte
2	22-48814	Molla per tubo scarico	Exhaust pipe spring	Ressort tube d'echappement	Auspuff Feder	Muelle tubo escape
3	22-04164	Marmitta	Muffler	Pot d'echappement	Schalldämpfer	Escape
4	13-49187	Distanziale silent-block	Spacer	Entretoise	Distanz	Distanciador
5	28-91946	Silent-block marmitta	Silent-block	Silent-block pot d'echappement	Silent-Block	Silent-block escape
6	13-49188	Distanziale	Spacer	Entretoise	Distanz	Distanciador

PER - FOR - POUR - FUER - POR 400/450/525cc

Pos	Number	Descrizione	Description	Description	Beschreibung	Descripción
1	29-16233	Tubo scarico	Exhaust tube	Tube vidange	Krümmen	Tubo escape parte
2	22-48814	Molla per tubo scarico	Exhaust pipe spring	Ressort tube d'echappement	Auspuff Feder	Muelle tubo escape
3	22-04163	Marmitta	Muffler	Pot d'echappement	Schalldämpfer	Escape
4	13-49187	Distanziale silent-block	Spacer	Entretoise	Distanz	Distanciador
5	28-91946	Silent-block marmitta	Silent-block	Silent-block pot d'echappement	Silent-Block	Silent-block escape
6	13-49188	Distanziale	Spacer	Entretoise	Distanz	Distanciador

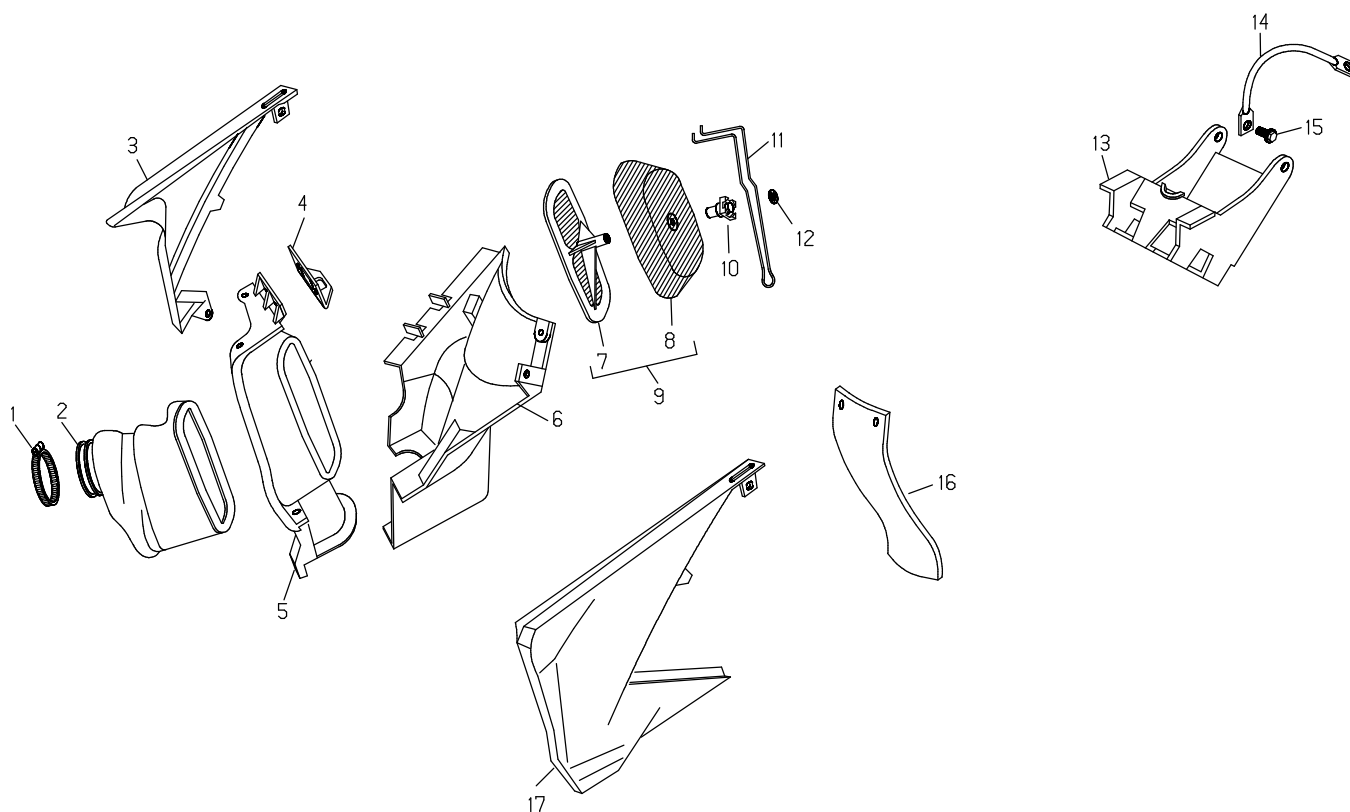

Pos	Number	Descrizione	Description	Description	Beschreibung	Descripción
1	15-14272	Fascetta raccordo aspiraz.	Clamp	Collier fixation	Schelle	Brida fijacion
2	22-13651	Manicotto scatola filtro	Rubber sleeve	Douille boite de filtre	Gummischlauch verga-luftfilter	Manguito caja filtro
3	28-12753-1-36	Scatola filtro dx	RH filter box	Boite de filtre droit	Filterkasten rechts	Caja filtro derecho
4	28-97021	Staffa aggancio molla filtro	Filter spring bracket	Etrier ressort filtre	Halter Federsfilter	Soporte muelle filtro
5	28-12751-1-36	Scatola filtro anteriore	Front filter box	Boite de filtre avant	Filterkasten vorne	Caja filtro anterior
6	28-12752-1-36	Scatola filtro posteriore	Rear filter box	Boite de filtre arriere	Filterkasten hinten	Caja filtro posterior
7	16-11215-8	Gabbia filtro aria	Filter cage	Grille filtre aire	Filter kafig	Jaula filtro aire
8	15-25091	Filtro aria	Air filter	Filtre aire	Luftfilter	Filtro aire
9	15-25091	Filtro aria	Air filter	Filtre aire	Luftfilter	Filtro aire
10	25-57197	Perno richiamo ferma-filtro	Filter pin	Pivot filtre	Filtershalter Pin	Eje filtro
11	22-48817	Molla fermafiltro	Filter spring	Ressort filtre	Filter Feder	Muelle filtro
12	27-74800	Rondella autobloccante 9	Washer 9	Rondelle 9	Scheibe 9	Arandela 9
13	28-11792-1-59	Scatola portabatteria	Battery box	Boite porte-batterie	Batteriekasten	Escatula bateria
14	18-01527	Impianto cavo massa	Electric equipment	Systeme electrique	Kabelbaum	Instalacion cable masa
15	11-48025	Bullone 6x16 ch 8 rs	Bolt 6x16	Boulon 6x16 ch8 rs	Bolzen 6x16	Tornillo 6x16 llave 8 rs
16	25-24413-1-59	Parascizzi scatola filtro	Filter box mudguard	Cache-taches boite de filtre	Spritzschutz Luftfilter	Faldon goma caja filtro
17	28-12754-1-36	Scatola filtro sx	LH filter box	Boite de filtre gauche	Filterkasten links	Caja filtro izquierdo

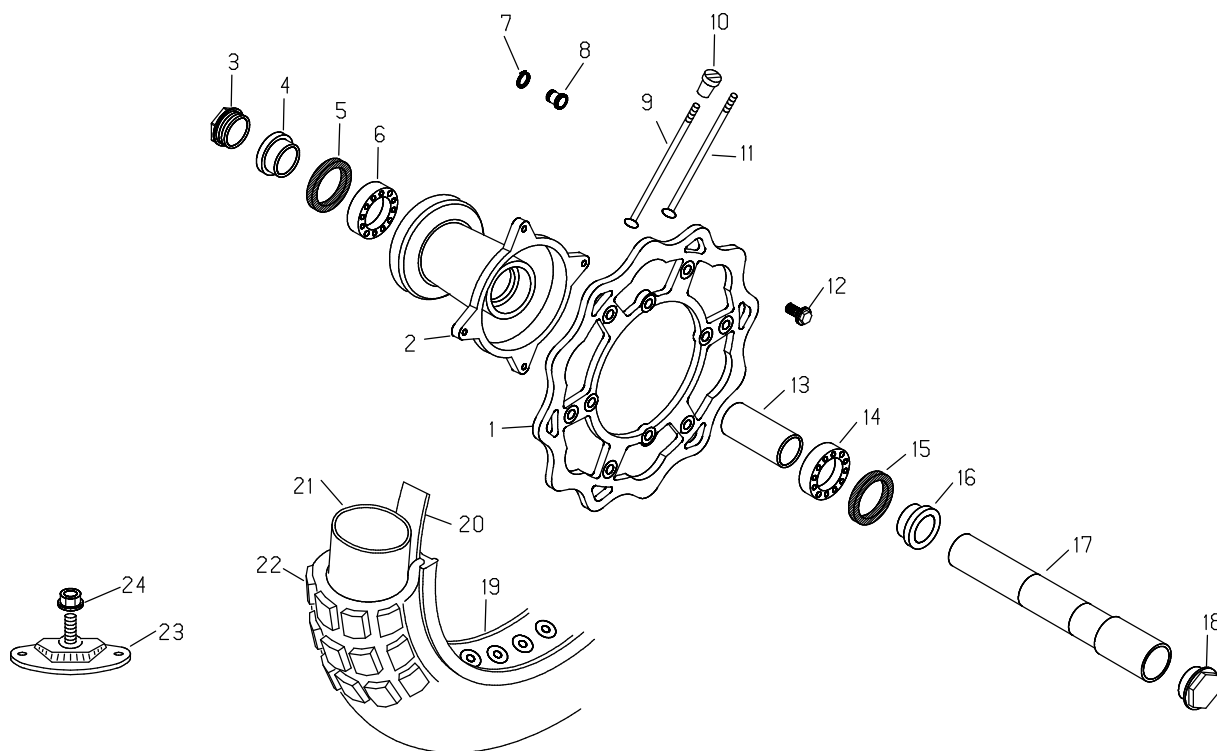

Pos	Number	Descrizione	Description	Description	Beschreibung	Descripción
1	13-39578	Disco freno anteriore	Front brake disk	Disque frein avant	Bremsscheibe vo.	Disco trial delantero
2	22-07249	Mozzo anteriore c/cuscinetti	Front hub with ballbearing	Moyeu avant avec roulements	Nabe vo.	Buje ant.c/cojinetes
3	29-10033	Tappo filett. perno ruota ant.	Front wheel pin plug	Bouchon pivot roue avant	Stopfen Pin Vorrad	Tapon eje rueda anterior
4	13-85519	Distanziale mozzo ant. Sx/Dx	LH and RH front hub spacer	Entretoise moyeu avant	Distanz li/re	Dist.,buje delt.04 izq. l/disco
5	10-66000	Anello paraolio 35x47x7	Oil seal 35x47x7	Joint spy 35x47x7	Wedi 35x47x7	Junta aceite 35x47x7
6	12-99520	Cuscinetto 30x47x9	Ball Bearing 30x47x9	Roulement 30x47x9	Kurbelwellenlager 30x47x9	Cojinete 30x47x9
7	28-22570	Seeger RA5	Seeger RA5	Seeger RA5	Seegerring RA5	Seeger RA5
8	22-11001	Magnete per sensore REED	Sensor REED magneto	Magneto capteur REED	Magnet für Sensor	magneto sensor REED
9	27-25051	Raggio 4x227	Spoke 4x227	Rayon 4x227	Speiche 4x227	Rayo 4x227
10	23-10122	Nipples M5/4,50	Nipples M5/4,50	Nipples M5/4,50	Nippel M5/4,50	Nipples M5/4,50
11	27-25052	Raggio 4x230	Spoke 4x230	Rayon 4x230	Speiche4x230	Rayo 4x230
12	11-52520	Bullone 8x14	Bolt 8x14	Boulon 8x14	Schraube 8x14	Tornillo 8.14
13	13-62708	Distanziale int. mozzo anter.	Front hub inner spacer	Entretoise int. moyeu avant	Distanzscheibe	Distanciador int buje del.
14	12-99520	Cuscinetto 30x47x9	Ball Bearing 30x47x9	Roulement 30x47x9	Kurbelwellenlager 30x47x9	Cojinete 30x47x9
15	10-66000	Anello paraolio 35x47x7	Oil seal 35x47x7	Joint spy 35x47x7	Wedi 35x47x7	Junta aceite 35x47x7
16	13-85519	Distanziale mozzo ant. Sx/Dx	LH and RH front hub spacer	Entretoise moyeu avant	Distanz li/re	Dist.,buje delt.04 izq. l/disco
17	25-55697	Perno ruota anteriore	Front wheel pin	Pivot roue avant	Vorderradachse	Eje rueda anterior
18	29-10032	Tappo perno ruota anteriore	Front wheel pin plug	Bouchon pivot roue avant	Stopfen Pin Vorrad	Tapon eje rueda anterior
19	12-42901	Cerchio 21x1,6x36 fori	Rim 21x1,6x36	Jante 21x1,6x36	Felge 21x1,6x36	Llanta 21x1,6x36
20	15-38200	Flap 21x25	Bead 21x25	Flap21x25	Felgenband 21x25	Flap cinta tapa radios 21.25
21	12-15005	Camera 2,50x21-2,75x21	Tube 2,50x21-2,75x21	Tube 2,50x21-2,75x21	Schlauch 2,50x21-2,75x21	Camara 2,50x21-2,75x21
22	12-81575	Copertura 90/90x21	Tire 90/90x21	Couverture 90/90x21	Reifen 90/90x21	Cubierta 90/90x21
23	15-17551	Fermafascioni per cerchio 21	Tire fastener	Caoutchouc serrure chambre	Reifen Halter	Agarre cubierta ant.
24	13-17120	Dado M8 flangiato	Nut M8	Ecrou M8	Mutter M8	Tuerca M8

RR-4T

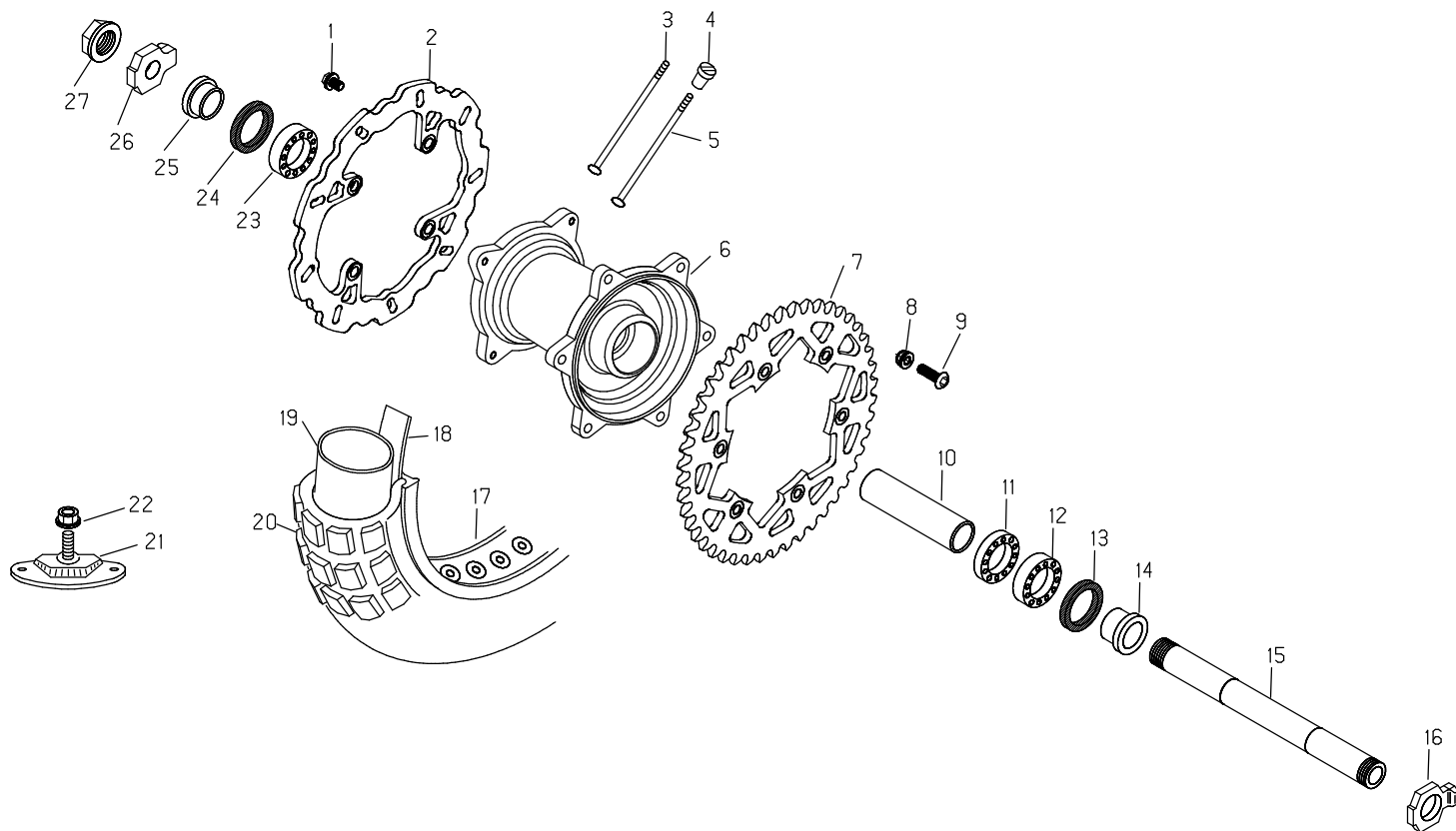

Pos	Number	Descrizione	Description	Description	Beschreibung	Descripción
1	11-52520	Bullone 8x14	Bolt 8x14	Boulon 8x14	Schraube 8x14	Tornillo 8.14
2	13-39574	Disco freno posteriore	rear brake disk	Disque frein arriere	Bremscheibe hi.	Disco trial trasero
3	27-25053	Raggio 4x190	Spoke 4x190	Rayon 4x190	Speiche 4x190	Rayo 4x190
4	23-10122	Nipples M5/4,50	Nipples M5/4,50	Nipples M5/4,50	Nippel M5/4,50	Nipples M5/4,50
5	27-25054	Raggio 4x196	Spoke 4x196	Rayon 4x196	Speiche 4x196	Rayo 4x196
6	22-08027	Mozzo posteriore c/cuscinetti	Rear hub with ballbearing	Moyeu arriere avec roulements	Hinterrad Nabe	Buje del. c/cojinetes
7	12-89496	Corona z.48	Rear sprocket z.48	Couronne z.48	Kettenrad z.48	Corona z-48
	12-89497	Corona z.50	Rear sprocket z.50	Couronne z.50	Kettenrad z.50	Corona z-50
	12-89498	Corona z.52	Rear sprocket z.52	Couronne z.52	Kettenrad z.52	Corona z-52
	12-89499	Corona z.45	Rear sprocket z.45	Couronne z.45	Kettenrad z.45	Corona z-45
8	13-17123	Dado M8 flangiato	Nut M8	Ecrou M8	Mutter M8	Tuerca M8
9	31-96815	Vite TSBCE 10x9	Screw	Vis	Schraube	Tornillo
10	13-62709	Distanziale int. mozzo poster.	Rear hub inner spacer	Entretoise int. moyeu arriere	Distanzscheibe	Distanciadore int. Buje tras.
11	12-99260	Cuscinetto 25x47x8	Ball bearing 25x47x8	Roulement 25x47x8	Lager 25x47x8	Cojinete 25x47x8
12	12-99280	Cuscinetto 25x47x12	Ball bearing 25x47x12	Roulement 25x47x12	Lager 25x47x12	Cojinete 25x47x12
13	10-66000	Anello paraolio 35x47x7	Oil seal 35x47x7	Joint spy 35x47x7	Wedi 35x47x7	Junta aceite 35x47x7
14	13-85522	Distanziale mozzo post. Sx	LH rear hub spacer	Entretoise moyeu arriere	Distanz li	Distanciadore buje tras.
15	25-55812	Perno ruota posteriore	Rear wheel pin	Pivot roue arriere	Hintenradachse	Eje rueda posterior
16	29-11866-1	Tendicatena sx	LH chain tensioner	Tendeur de chaine gauche	Kettenspanner li.	Tensor cadena izquierdo
17	12-42902	Cerchio 18x2,15x36 fori	Rim 18x2,15x36	Jante 18x2,15x36	Felge 18x2,15x36	Llanta 18x2,15x36
18	15-36000	Flap 17/18x25	Bead 17/18x25	Flap 17/18x25	Felgenband 17/18x25	Flap cinta tapa radios 17/18x25
19	12-15006	Camera 4,00x18	Tube 4,00x18	Tube 4,00x18	Schlauch 4,00x18	Camara 4,00x18
20	12-81584	Copertura 4,00x18	Tire 4,00x18	Couverture 4,00x18	Reifen 4,00x18	Cubierta 4,00x18
21	15-17531	Fermafascioni per cerchio 18	Tire fastener	Caoutchouc serrure chambre	Reifen Halter	Agarre cubierta ant.
22	13-17120	Dado M8 flangiato	Nut M8	Ecrou M8	Mutter M8	Tuerca M8
23	12-99280	Cuscinetto 25x47x12	Ball bearing 25x47x12	Roulement 25x47x12	Lager 25x47x12	Cojinete 25x47x12
24	10-66000	Anello paraolio 35x47x7	Oil seal 35x47x7	Joint spy 35x47x7	Wedi 35x47x7	Junta aceite 35x47x7
25	13-85521	Distanziale mozzo post. Dx	RH rear hub spacer	Entretoise moyeu arriere	Distanz li	Distanciadore buje tras.
26	29-11865-1	Tendicatena dx	RH chain tensioner	Tendeur de chaine droit	Kettenspanner re.	Tensor cadena derecho
27	13-27120	Dado spec. perno ruota post.	Rear wheel axle special nut	Ecrou spec. Pivot roue arr.	Spezial Mutter Rad hinten	Tuerca esp. Rueda posterior

RR-4T

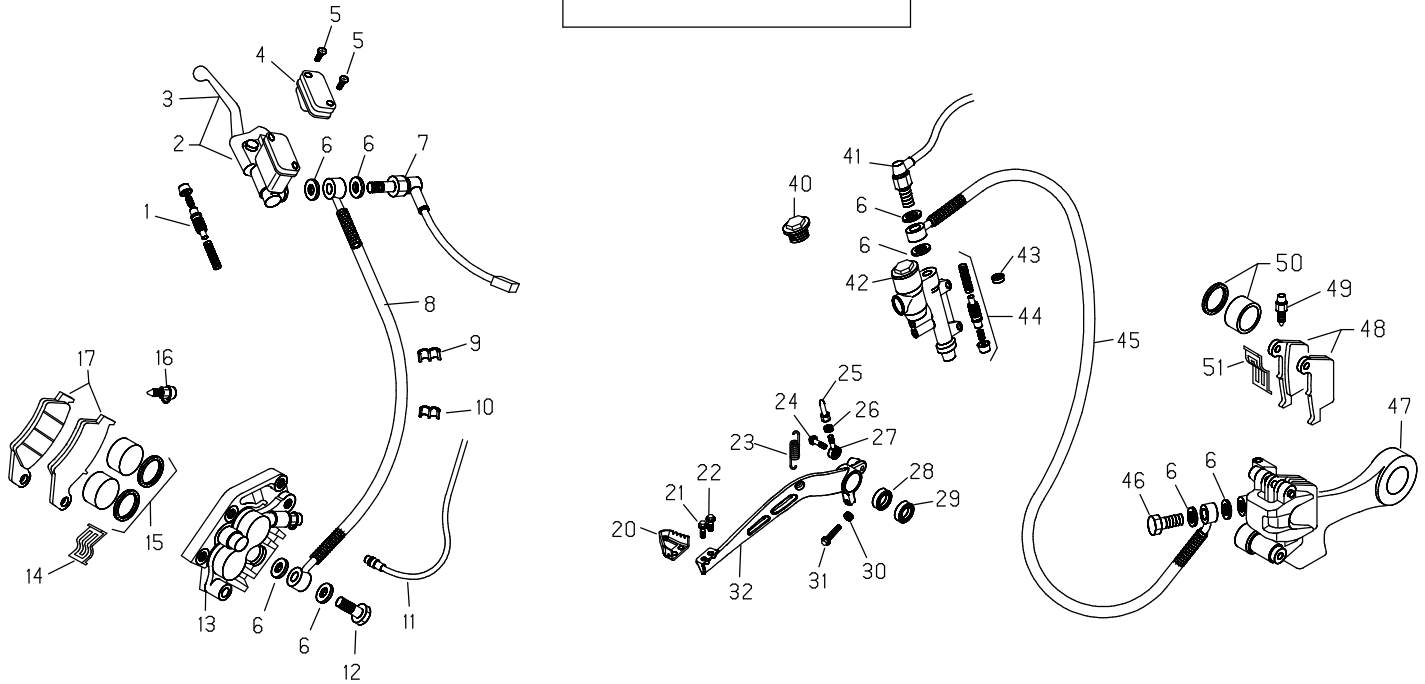

Pos	Number	Descrizione	Description	Description	Beschreibung	Descripción
1	20-08258	Kit pistoncino compl. pompa	Pump piston assy	Jeu piston complet pompe	Kuppl pompe kolben	Juego piston compl. Bomba
2	21-02057	Leva com. freno anter.	Front brake lever	Levier complet frein avant	Bremsarmatur	Bomba freno delantero
3	21-27104	Leva freno anter.nuda	Front brake lever only	Levier frein avant nue	Bremshebel	Maneta freno
4	20-08259	Kit coperchio serbatoio pompa	Pump tank cover assy	Jeu couvercle reservoir pompe	Reparaturatz Deckel Pumpe	Juego tapon deposito bomba
5	31-23402	Vite coperchio serbatoio olio	Screw	Vis couvercle reservoir huile	Schraube	Tornillo tapa deposito aceite
6	16-50510	Guarnizione 10x15x1 in rame	Gasket 10x15x1 copper	Joint 10x15x1 cuivre	Dichtung 10x15x1 Kupfer	Junta 10.15.1 (cobre)
7	18-89621	Interruttore stop	Stop switch	Intermittence stop	Stopplightschalter	Interruptor stop/arranque
8	29-09101	Tubo freno anteriore	Front brake hose	Tube frein avant	Bremsleitung	Tubo freno delantero
9	25-24443	Passacavo 6/6	Fair lead 6/6	Passe-fils 6/6	Kabelführung 6/6	Pasa-cable 6/6
10	25-24442	Passacavo 6/8	Fair lead 6/8	Passe-fils 6/8	Kabelführung 6/8	Pasa-cable 6/8
11	28-79011	Sensore REED	REED sensor	Sensor REED	Sensor	Sensore REED
12	11-65053	Bullone forato 10x1,25	Special bolt	Boulon 10x1,25 x tube frein	Hohlschraube F.Bremse	Tornillo esp. talad.10.1,25
13	25-03056	Pinza freno anteriore	Front brake pleir	Pince frein avant	Bremszange vorne	Pinza freno anterior
14	22-32207	Molla ferma pastiglie pinza	Brake pads spring for pliers	Ressort arret plaquettes	Haltefeder	Muelle pastillas pinza
15	20-02716	Kit pistoncini e guarniz. Pinza	Piston e oil seal for pliers	Jeu petit pistons et joint pinces	Reparaturatz Bremszange	Juego piston y guarnicion pinza
16	28-91001	Sfiato pinza freno	Breather pipe	Event pince frein	Bremszange Entlüftung	Aliento pinzas freno
17	25-25361	Pastiglie per pinza	Brake pads	Plaquettes pince	Bremsbeläge hinten	Pastillas pinza
20	22-90053	Mozzetto con pedana	Footrest hub	Moyeu a/repose pieds	Rasten Nabe Fußbremshebel	Puntera pedal freno
21	11-46251	Bullone 5x12 ch 8	Bolt 5x12	Boulon 5x12 ch 8	Bolzen 5x12	Tornillo 5x12 llave 8
22	11-46251	Bullone 5x12 ch 8	Bolt 5x12	Boulon 5x12 ch 8	Bolzen 5x12	Tornillo 5x12 llave 8
23	22-48813	Molla ritorno pedale freno	Return brake pedal spring	Ressort de retour frein	Bremspedal Feder	Muelle ritorno palanca freno
24	11-50010	Bullone 6x25 ch 8 rs	Bolt 6x25	Boulon 6x25 ch 8 rs	Bolzen 6x25	Tornillo 6.25 ch 8 rs
25	10-84094	Asta com.pompa freno post.	Rear brake rod	Tige de commande pompe frein	Betaetigungsstange Bremse hi.	Varilla bomba freno post.
26	13-11500	Dado 6x3,5 ch10	Nut 6x3,5	Ecrou 6x3,5 ch10	Mutter 6x3,5	Tuerca 6x3,5 llave 10
27	28-93254	Snodo sferico per asta freno	Brake bracket spheric junction	Joint a rotule etrier frein	Kugelgelenk	Rotula sferica asta freno
28	12-93388	Cuscinetto 8x22x7	Ball bearing 8x22x7	Roulement 8x22x7	Kugellager 8x22x7	Cojinete 8x22x7
29	12-93388	Cuscinetto 8x22x7	Ball bearing 8x22x7	Roulement 8x22x7	Kugellager 8x22x7	Cojinete 8x22x7
30	13-13020	Dado autoblocc. Basso M6	Nut M6	Ecrou M6	Mutter M6	Tuerca M6
31	11-50030	Bullone 6x30 ch 8 rs	Bolt 6x30	Boulon 6x30 ch 8 rs	Bolzen 6x30	Tornillo 6.30 ch 8 rs
32	25-28087	Pedale freno	Rear brake	Pedale frein	Bremshebel hi.	Pedal freno
40	20-08263	Kit tappo compl. pompa freno	Brake pump complete cover kit	Jeu couvercle complete pompe frein	Reparaturatz Deckel Bremspumpe	Juego tapon completo bomba freno
41	18-89622	Interruttore stop	Stop switch	Intermittence stop	Stopplightschalter	Interruptor stop/arranque
42	25-91176	Pompa freno posteriore	Rear brake pump	Pompe frein arriere	Bremspumpe hi.	Bomba freno trasera
43	10-67335	Anello OR pompa freno	Brake pump OR	OR pompe de frein	O-Ring Bremspumpe	Junta torica bomba freno
44	20-08264	Kit pistoncino pompa freno	Brake pump piston kit	Jeu piston pompe frein	Reparaturatz Kolben Bremspumpe	Juego piston bomba freno
45	29-09427	Tubo freno disco posteriore	Rear brake hose	Tube frein a disque arriere	hi. Bremsleitung	Tubo freno disco post.
46	11-65053	Bullone forato 10x1,25	Special bolt	Boulon 10x1,25 x tube frein	Hohlschraube F.Bremse	Tornillo esp. talad.10.1,25
47	25-03066	Pinza freno posteriore	Pliers front brake	Pince frein arriere	Bremszange hinten	Pinza freno post.
48	25-25362	Pastiglie per pinza	Brake pads	Plaquettes pince	Bremsbeläge hinten	Pastillas pinza
49	28-91002	Sfiato pinza freno	Breather pipe	Event pince frein	Bremszange Entlüftung	Aliento pinzas freno
50	20-02717	Kit pistoncini e guarniz. Pinza	Piston e oil seal for pliers	Jeu petit pistons et joint pinces	Reparaturatz Bremszange	Juego piston y guarnicion pinza
51	22-32208	Molla ferma pastiglie pinza	Brake pads spring for pliers	Ressort arret plaquettes	Haltefeder	Muelle pastillas pinza

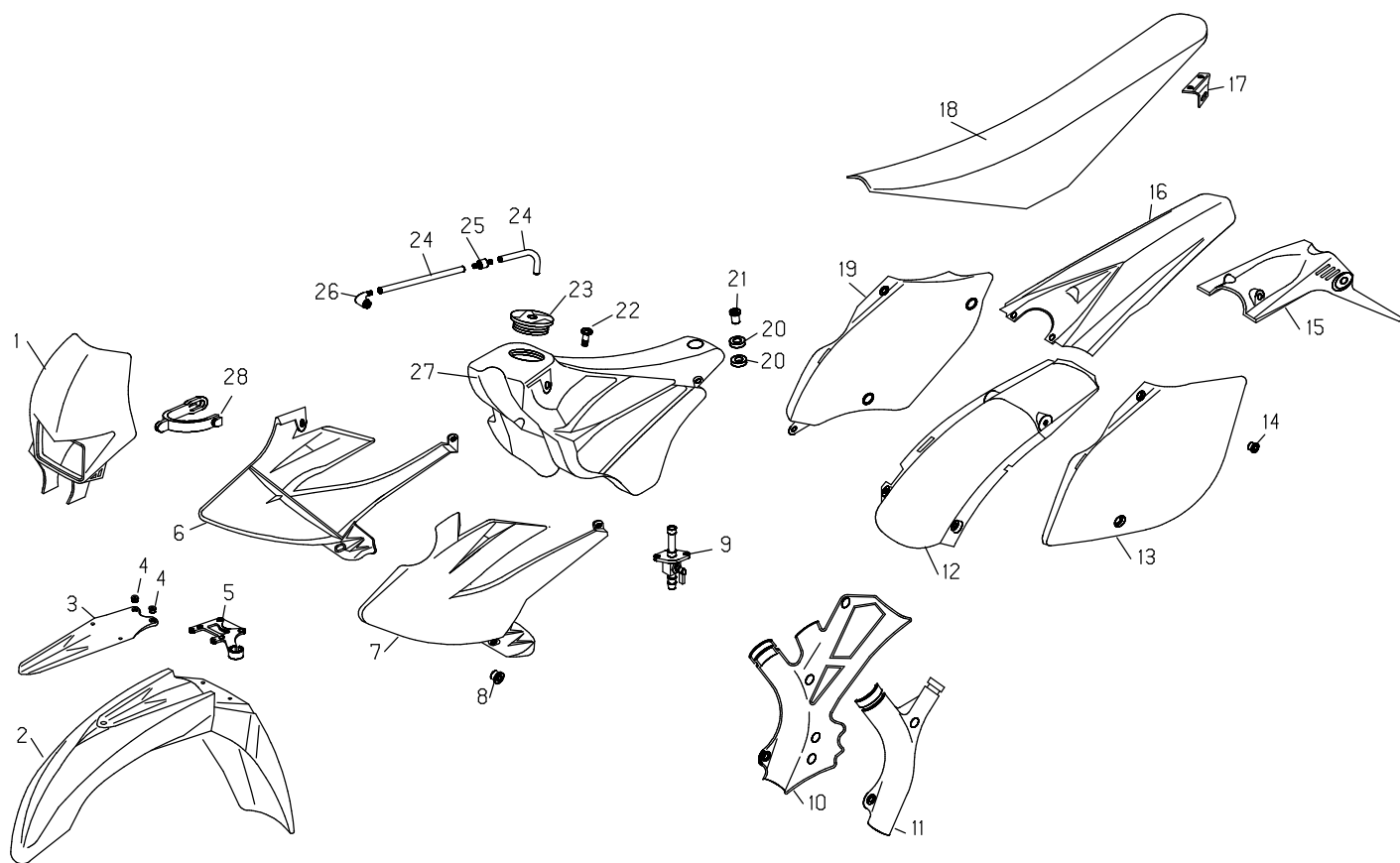

Pos	Number	Descrizione	Description	Description	Beschreibung	Descripción
1	22-28471-1-97	Mascherina portafaro	Headlight holder	Cache porte-phare	Lampenmaske	Portafaro ant. con adhesivo
2	25-15201-1-97	Parafango anteriore	Front fender	Garde-boue avant	Vorderradkotflügel	Guardabarros delantero
3	28-98278-1-33	Supporto parafango anteriore	Front fender bracket	Support garde-boue avant	Kotflügelhalter vorne	Soporte guardabarros ant.
4	13-49190	Distanziale	Spacer	Entretoise	Distanz	Distanciador
5	25-57255-1-36	Piastra per tubo freno anter.	Front brake tube plate	Plaque tube frein avant	Halteplatte Bremsschlauch	Placa tubo freno anterior
6	15-23203-1-97	Fianchetto serbatoio dx	RH tank panel	cote lateral reservoir droite	Benzintankseite re.	Flanco derecho deposito
7	15-23202-1-97	Fianchetto serbatoio sx	LH tank panel	Cote lateral reservoir gauche	Benzintankseite li.	Flanco izquierdo deposito
8	13-54510	Distanziale	Spacer	Entretoise	Distanz	Distanciador
9	27-79831	Rubinetto benzina	Petcoq	Robinet melange	Benzinhahn	Grifo gasolina
10	25-98925	Protezione telaio dx	RH frame protection	Protection cadre droit	Rahmenschutz re.	Protection chasis derecho
11	25-98926	Protezione telaio sx	LH frame protection	Protection cadre gauche	Rahmenschutz li.	Protection chasis izquierdo
12	25-24657-1-36	Passaruota	Rear wheel house	Passe-roue	Radführung	Pasarueda
13	15-19863-1-97	Fiancata portanumero sx	LH side panel	Cote lateral gauche porte-numero	Nummershalterseite li.	Flanco lateral izquierdo
14	13-62000	Distanziale	Spacer	Entretoise	Distanz	Distanciador
15	25-94486-1-36	Portatarga	Number plate holder	Porte-plaque	Nummernschildhalter	Porta-matricula
16	25-19586-1-97	Parafango posteriore	Rear fender	Garde-boue arriere	Hinterradkotflügel	Guardabarros tras.
17	28-95233	Staffa fissaggio sella	Fixing seat plier	Etrier fixation selle	Halter Sattel	Soporte fijacion sillin
18	28-02637	Sella	Seat	Selle	Sattel	Sillin
19	15-19862-1-97	Fiancata portanumero dx	RH side panel	Cote lateral droite porte-numero	Nummershalterseite re.	Flanco lateral derecho
20	29-10615	Tampone carena scooter	Scooter fairing pad	Tampon carenage scooter	Rollersaufbau Schlegel	Tampon casco del buque scooter
21	13-49184	Distanziale serbatoio	Tank spacer	Entretoise reservoir	Distanz Benzintank	Distanciador deposito
22	31-89010	Vite spec. bloccaggio sella	Seat locking screw	Vis blocage selle	Schraube	Tornillo bloqueo sillin
23	29-10501	Tappo serb. benzina	Gasoline tank plug	Bouchon reservoir	Tankdeckel	Tapon deposito gasolina
24	29-15811	Tubo benzina 5x9	Gasoline tube 5x9	Tube essence 5x9	benzinschlauch 5x9	Tubo gasolina 5x9
25	31-02170	Valvola sfiato serbatoio	Tank exhaust valve	Valve echappement reservoir	Entlüftungssicherung Tank	Valvula escape deposito
26	27-23470	Raccordo per sfiato	Breather pipe hose	Raccord pour event	Entlüftungsschlauch	Enlace aliento
27	28-06078-1	Serbatoio benzina	Gasoline tank	Reservoir	Benzintank	Deposito gasolina
28	14-40081	Elastico fissaggio mascherina	Headlight holder elastic rubber	Elastique de fixation cache phare	Befestigungsband Lichtschildche	Elastico

RR-4T

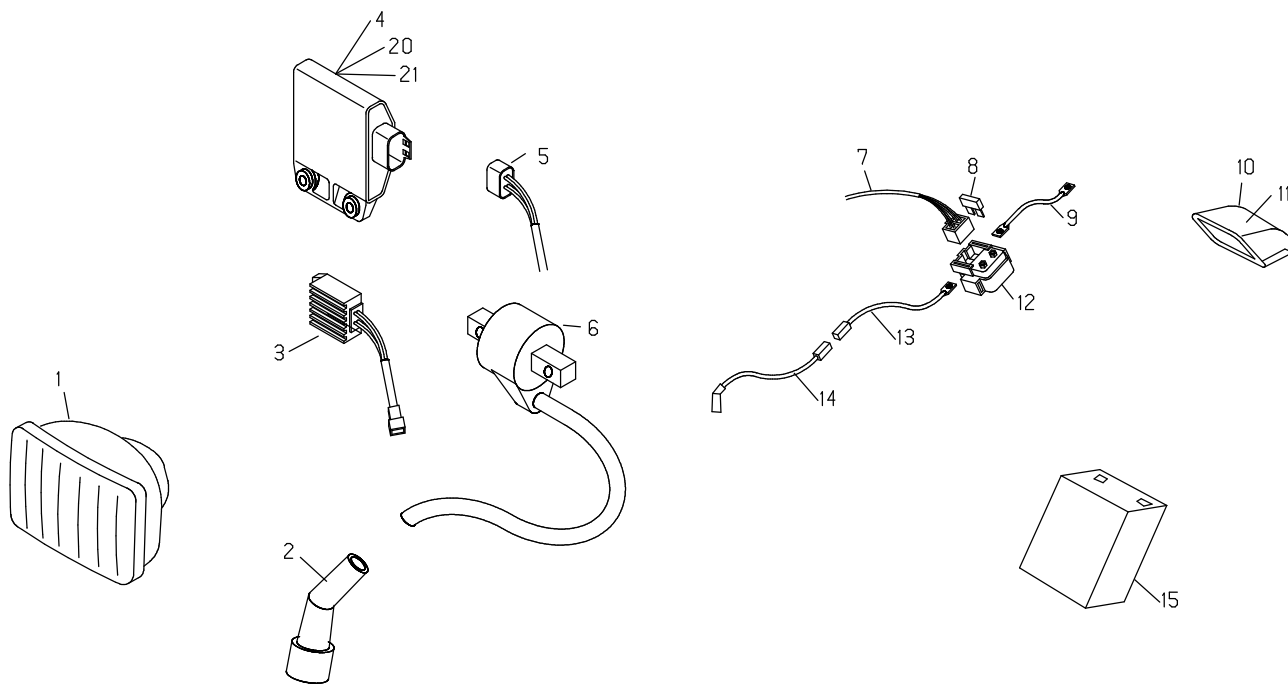

Pos	Number	Descrizione	Description	Description	Beschreibung	Descripción
1	16-46202	Gruppo ottico RR-4T	Headlight RR4T	Groupe optique	Optischer Block	Grupo optico
	16-46203	Gruppo ottico RR-4T	Headlight	Groupe optique	Scheinwerfer supermotard	Grupo optico RR-4T
2	27-13553	Raccordo candela	Spark plug raccor	Raccord bugie	Zündkerzenstecker	Enlace bujia
3	27-28101	Regolatore	Regulator	Regulateur	Regler	Regulador
4	12-41847-8	Centralina digitale con targh.	CDI unit	CDI	CDI mit Schild	CDI
5	18-01536	Impianto centralina	CDI electric equipment	CDI systeme electrique	CDI Kabelbaum	Instalacion CDI
6	11-20694-8	Bobina con targhetta	Coil with plate	Bobine avec plaquette	Zündspule mit Schild	Bobina con placa
7	18-01537	Impianto posteriore	rear electric equipment	systeme electrique arriere	Kabelbaum hi.	Instalacion posterior
8	15-66601	Fusibile 10A	Fuse 10A	Fusible 10A	Schmelzsicherung	Fusible 10A
9	18-01529	Impianto cavo positivo batteria	Electric equipment	Systeme electrique	Kabelbaum	Instalacion cable positivo bateria
10	15-01766	Fanalino posteriore	Rear light	feu arriere	Rücklicht Glas	Piloto trasero
11	12-81703	Coppetta fanalino posteriore	Indicator lens	Boite feu arriere	Rücklichtschutz	Proteccion luz posterior
12	27-28471	relais avviamento motore	Starter relais	Relais demarrage	Relais Starter	Relais arranque
13	18-01528	Impianto relè	Electric equipment	Systeme electrique relais	Kabelbaum	Instalacion relais
14	18-01538	Impianto motorino avviamento	starter electric equipment	system electrique demarrage	Kickstarter Kabelbaum	Instalacion arranque
15	11-15415	Batteria	Battery	Batterie	Batterie	Bateria

PER 450cc - FOR 450cc - POUR 450cc - FUER 450cc - POR 450cc

Pos	Number	Descrizione	Description	Description	Beschreibung	Descripción
20	12-41848-8	Centralina digitale con targh.	CDI unit	CDI	CDI mit Schild	CDI

PER 400/525cc - FOR 400/525cc - POUR 400/525cc - FUER 400/525cc - POR 400/525cc

Pos	Number	Descrizione	Description	Description	Beschreibung	Descripción
21	12-41849-8	Centralina digitale con targh.	CDI unit	CDI	CDI mit Schild	CDI

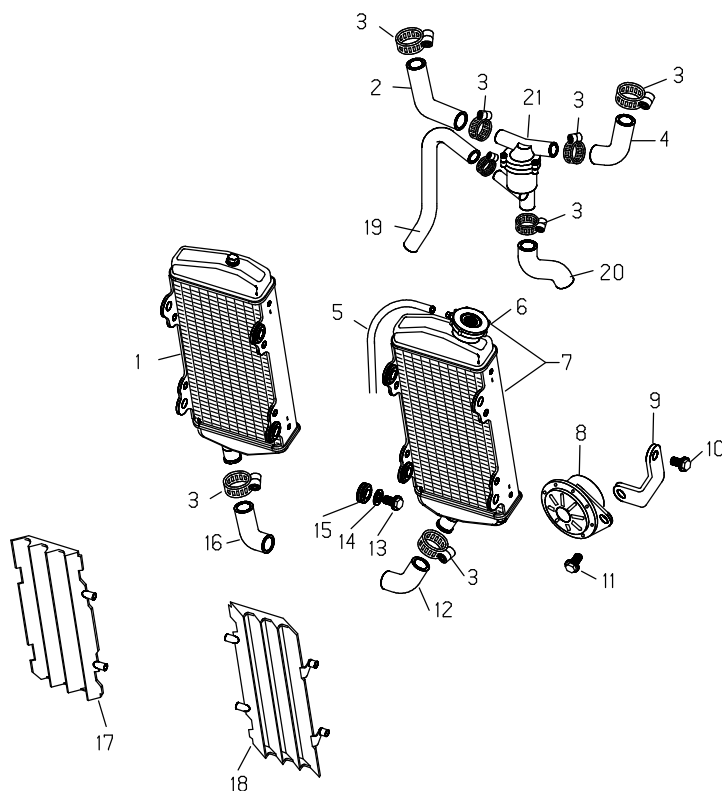

Pos	Number	Descrizione	Description	Description	Beschreibung	Descripción
1	27-23742	Radiatore dx	RH radiator	Radiateur droit	Kühler re.	Radiador derecho
2	29-15934	Tubo radiatore dx	RH radiator tube	Tube radiateur droit	Wasserschlauch Kühler re.	Tubo radiador derecho
3	15-15240	Fascetta 19x28	Clamp 19x28	Collier 19x28	Schelle 19x28	Brida 19/28
4	29-15933	Tubo radiatore sx	LH radiator tube	Tube radiateur gauche	Wasserschlauch Kühler li.	Tubo radiador izquierdo
5	29-15811	Tubo benzina 5x9	Gasoline tube 5x9	Tube essence 5x9	benzinschlauch 5x9	Tubo gasolina 5x9
6	29-01823	Tappo radiatore	Water tank cover	Bouchon radiateur	Kühlwasserdeckel	Tapon radiador
7	27-23743	Radiatore sx	LH radiator	Radiateur gauche	Kühler li.	Radiador izquierdo
8	10-09172	Avvisatore acustico	Horn	Avertisseur acustique	Hupe	Avisador acustico
9	28-97255	Staffa supporto avvisat. acust.	horn support bracket	Etrier support clacson	Klemme Hupe	Soporte clacson
10	11-47015	Bullone 6x12 ch 8 rs	Bolt 6x12	Boulon 6x12 ch 8 rs	Bolzen 6x12	Tornillo 6x12 llave 8 rs
11	11-47015	Bullone 6x12 ch 8 rs	Bolt 6x12	Boulon 6x12 ch 8 rs	Bolzen 6x12	Tornillo 6x12 llave 8 rs
12	29-15935	Tubo inferiore radiatore sx	LH lower radiator tube	Tube radiateur gauche inf.	Wasserschlauch Kühler unten/re.	Tubo radiador izquierdo inferior
13	11-47015	Bullone 6x12 ch 8 rs	Bolt 6x12	Boulon 6x12 ch 8 rs	Bolzen 6x12	Tornillo 6x12 llave 8 rs
14	27-42000	Rondella 6x18	Washer 6x18	Rondelle 6x18	Scheibe 6x18	Arandela 6x18
15	16-34911	Gommino radiatore	Radiator rubber	Caoutchouc radiator	Kühler Gummi	Goma radiador
16	29-15936	Tubo inferiore radiatore dx	RH lower radiator tube	Tube radiateur droit inf.	Wasserschlauch Kühler unten/li.	Tubo radiador derecho inferior
17	16-45544-1-36	Griglia radiatore dx	RH radiator protection	Grille radiateur droite	Kühlergrill re.	Rejilla radiador derecha
18	16-45545-1-36	Griglia radiatore sx	LH radiator protection	Grille radiateur gauche	Kühlergrill li.	Rejilla radiador izquierda
19	29-15938	Tubo inferiore termostato	Lower thermostat tube	Tube inferieur interrupteur thermique	Thermostatschlauch unten	Tubo termostato inferior
20	29-15937	Tubo termostato	Thermostat tube	Tube interrupteur thermique	Thermostatschlauch	Tubo termostato
21	29-11991	Termostato completo	Complete thermostat	Interrupteur thermique complet	Kompletter Thermostat	Termostato completo

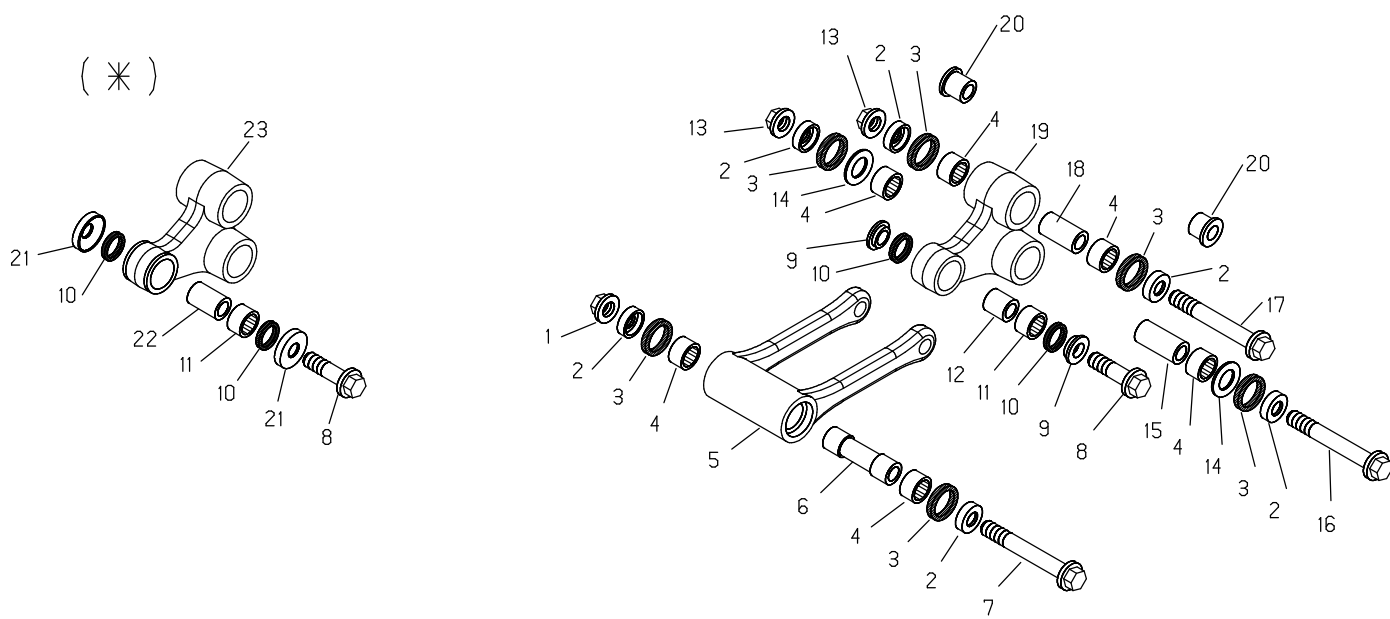

Pos	Number	Descrizione	Description	Description	Beschreibung	Descripción
1	13-21130	Dado autoblocc. flangiato 12	Nut 12	Ecrou 12	Mutter 12	Tuerca 12
2	28-14080	Scodellino bilanciare	Rocking lever cup	Cuvette balancier	Schwinghebel Teller	Sopero balance
3	10-64480	Anello paraolio 25x32x4	Oil seal 25x32x4	Joint spy 25x32x4	Wedi 25x32x4	Junta aceite 25x32x4
4	11-22055	Boccola a rulli 20x26x16	Needle bearing 20x26x16	Douille a roulements 20x26x16	Nadellager 20x26x16	Cojinete 20x26x16
5	11-19738	Bielletta	Connecting rod	Biellette	Pleuelstange	Biela
6	13-62814	Distanziale 12x20x77,5	Spacer 12x20x77,5	Entretoise 12x20x77,5	Distanz 12x20x77,5	Distanciador 12x20x77,5
7	11-63996	Bullone spec. Bilanciere	Bumper rod bolt	Boulon balancier	Spezial Schwinghebelsbolzen	Tornillo balance
8	11-62050	Bullone 10x45	Bolt 10x45	Boulon 10x45	Bolzen 10x45	Tornillo 10.45
9	11-22053	Boccola per bilanciere	Bumper rod bush	Bague balancier	Buchse für Schwinghebel	Junta balance
10	10-62030	Anello paraolio 18x24x3	Oil seal 18x24x3	Joiny spy 18x24x3	Wedi 18x24x3	Junta aceite 18x24x3
11	11-22054	Boccola a rulli 18x24x16	Needle bearing 18x24x16	Douille a roulements 18x24x16	Nadellager 18x24x16	Cojinete 18x24x16
12	11-22053	Boccola per bilanciere	Bumper rod bush	Bague balancier	Buchse für Schwinghebel	Junta balance
13	13-21130	Dado autoblocc. flangiato 12	Nut 12	Ecrou 12	Mutter 12	Tuerca 12
14	27-73635	Rondella spess. 20x30x1	Washer 20x30x1	Rondelle epaisseur 20x30x1	Scheibe 20x30x1	Arandela 20x30x1
15	13-62813	Distanziale 12x20x50	Spacer 12x20x50	Entretoise 12x20x50	Distanz 12x20x50	Distanciador 12x20x50
16	11-63992	Bullone spec. Bilanciere	Bumper rod bolt	Boulon balancier	Spezial Schwinghebelsbolzen	Tornillo balance
17	11-63995	Bullone spec. Bilanciere	Bumper rod bolt	Boulon balancier	Spezial Schwinghebelsbolzen	Tornillo balance
18	13-62812	Distanziale 12x20x40	Spacer 12x20x40	Entretoise 12x20x40	Distanz 12x20x40	Distanciador 12x20x40
19	11-20474	Bilanciere	Bumper rod	Balancier	Schwinghebel	Balance
20	11-22052	Boccola per forcellone	Swinging arm bush	Douille bras oscillant	Buchse für Schwinde	Casquillo basculante

(*) Per telai	dal N.	al N.				
From frame	from	to				
No.serie	du	jusqu'au				
Fahr gestell nr.	von	bis				
Chasis	desde	a				
			ZD3E1000040000001	ZD3E1000040000037	250 cc	
			ZD3E1010040000001	ZD3E1010040000069	400 cc	
			ZD3E1020040000001	ZD3E1020040000152	450 cc	
			ZD3E1030040000001	ZD3E1030040000054	525 cc	

Pos	Number	Descrizione	Description	Description	Beschreibung	Descripción
21	28-14091	Scodellino bilanciare	Rocking lever cup	Cuvette balancier	Schwinghebel Teller	Sopero balance
22	13-47960	Distanziale 10x18x23	Spacer 10x18x23	Entretoise 10x18x23	Distanz 10x18x23	Distanciador 10.18.23
23	11-20475	Bilanciere	Bumper rod	Balancier	Schwinghebel	Balance



PARTICOLARI NON FIGURANTI
 SUPPLEMENTARY OARTS LIST
 PARTICULIERS PAS MENTIONNES
 NICHT VERZECHNETE TEILE
 PARTICULARES NO FIGURADOS

Pos	Number	Descrizione	Description	Description	Beschreibung	Descripción
	11-05666	Borsetta arnesi	Tools bag	Sachocce avec outils	Werkzeugtasche	-
	12-33062	Catadiottro laterale	Lateral reflector	Catadioptré lateral	Seitlicher Rückstrahler	Reflector lateral
	12-33086	Catadiottro posteriore	Rear reflector	Catadioptré arriere	Rückstrahler hinten	Reflector posterior
	13-31461	Decalco (serie)	Decalc	Autocollant	Aufkleber	adhesivos
	18-12611	Indicatore direzione ant. dx	RH front indicator	Indicateur avant droit	Blinker vorne re.	Flecha anterior derecha
	18-12614	Indicatore direzione ant. sx	LH front indicator	Indicateur avant gauche	Blinker vorne li.	flecha anterior izquierda
	18-12621	Indicatore direzione post. dx	RH rear indicator	Indicateur arriere droit	Blinker hinten re.	flecha posterior derecha
	18-12624	Indicatore direzione post. sx	LH rear indicator	Indicateur arriere gauche	Blinker hinten li.	flecha posterior izquierda
	20-09051	Kit getti carburatore RR-4T	Carburetor jets kit	Jeu jets carburateur	Reparaturatz Vergasersdüsen	Kit de lanzamientos carburador
	20-11210	Kit protez. telaio in carbonio	Frame carbon protection kit	Jeu protections cadre en carbon	Kit Karbonrahmenschutz	Juego protect. Chasis en carbono
	20-11211	Kit distanziali targa	Number plate spacer kit	Jeu entretoises plaque	Kit Nummernschild Distanz	Juego distanciador matricula
	20-11212	Kit spugne protez. Telaio	Frame spognes protection kit	Jeu sponges protect. Cadre	Kit Schwamm Rahmenschutz	Juego esponjas protect. Chasis
	25-99215	Pulsante comando "MODE"	Pushbutton "MODE" digital speedometer	Pulsant commande "MODE"	Schalter "MODE"	Boton mando "MODE"
	27-02559-0-57	Ruota anteriore	Front wheel	Roue avant	Vorderrad	Rueda delantera
	27-02559-4-57	Ruota anteriore p/montata	Front wheel ass.	Roue avant p/monte'	Vormontiertes vorderrad	Rueda delantera montada
	27-04808-0-57	Ruota posteriore	Rear wheel	Roue arriere	Hinterrad	Rueda trasera
	27-04808-4-57	Ruota posteriore p/montata	Front wheel ass.	Roue arriere p/monte'	Vormontiertes hinterrad	Rueda trasera montada
	28-12755-8-36	Scatola filtro completa	Air filter box assembly	Boite de filtre complet monté	Filterkasten montiert	Caja filtro aire completa montada
	28-92927	Specchio retrovisore dx	RH rear view mirror	Retroviseur droit	Rückspiegel re.	Espejo retrovisor derecho
	28-92928	Specchio retrovisore sx	LH rear view mirror	Retroviseur gauche	Rückspiegel li.	Espejo retrovisor izquierdo
	28-98476	Supporto targa	Licenze plate bracket	Support plaque	Nummernschildhalter	Soporte matricula